

# CONTROL VALVE PN16

## SERIES SERIE VLA300, VLA400 AND VLB300

ESBE flanged control valves series for PN16, DN15-150.

2-way valves: VLA325, VLB325 and VLA425.

3-way valves: VLA335 and VLB335



VLA325  
Flange PN16



VLB325  
Flange PN16



VLA425  
Flange PN16, pressure-balanced plug



VLA335  
Flange PN16



VLB335  
Flange PN16

### MEDIA

These valves can handle the following types of media:

- Hot and cold water.
- Water with antifreeze additives such as glycol.

If the valve is used for media at temperatures below 0°C (32°F), it should be equipped with a stem heater in order to prevent ice formation on the valve stem. The stem heater ALF802 is fixed on the actuator fixing point.

These control valves are used to control fluids belonging to the group showed in the table in accordance to article 9 of 97/23/CE (PED) directive, in air-conditioning, thermoventilation and heating plants and in industrial processes; therefore they cannot be used as safety valves.

### VALVE MOUNTING

Before mounting the valve, make sure pipes are clean, free from welding slags. The pipes must be perfectly aligned with the valve body and not subject to any vibrations. For installations on plants with high temperature fluids (overheated water, diathermic oil) always use expansion joints to avoid dilatation of pipes to stress the valve body.

Install the valves with the actuator in vertical position for fluid temperature up to 120°C, with higher temperatures they must be mounted horizontally.

### CONTROL VALVE DESIGNED FOR

- Heating
- Comfort Cooling
- Solar heating
- Ventilation
- District Heating
- District Cooling

### SUITABLE ACTUATORS

- ALB140
- ALD12x, ALD22x DN15-50
- ALD24x, ALD24x DN65-150
- ALF13x DN15-50
- ALF26x DN15-150
- ALF36x DN15-150
- ALF46x DN65-150

### ACCESSORIES DN 15 - 50

Adaptor kit \_\_\_\_\_ Siemens SQX, Art. No. 2600 07 00

#### TECHNICAL DATA, DN15-50

Type: \_\_\_\_\_ 2- and 3-way plug valve  
 Pressure class: \_\_\_\_\_ PN 16  
 Flow characteristic A-AB: \_\_\_\_\_ EQM  
 Flow characteristic B-AB: \_\_\_\_\_ Complementary  
 Stroke: \_\_\_\_\_ 20 mm  
 Rangeability  $K_v/K_v^{min}$ : \_\_\_\_\_ see graph  
 Leakrate A-AB: \_\_\_\_\_ Tight sealing  
 Leakrate B-AB: \_\_\_\_\_ Tight sealing  
 $\Delta P_{max}$ : \_\_\_\_\_ see graph  
 Media temperature: \_\_\_\_\_ max. +130°C  
 \_\_\_\_\_ min. -20°C  
 Connection: \_\_\_\_\_ Flange, ISO 7005-2

Material  
 Body: \_\_\_\_\_ Nodular iron EN-JS 1030  
 Stem: \_\_\_\_\_ Stainless steel SS 2346  
 Plug: \_\_\_\_\_ Brass CW602N  
 Seat: \_\_\_\_\_ Nodular iron EN-JS 1030  
 Blind plug: \_\_\_\_\_ Brass CW602N  
 Seat seal: \_\_\_\_\_ EPDM  
 Packing box seal: \_\_\_\_\_ PTFE/EPDM

CE DN15-50 PED 97/23/EC, article 3.3

#### TECHNICAL DATA, DN65-150

Type: \_\_\_\_\_ 2- and 3-way plug valve  
 Pressure class: \_\_\_\_\_ PN 16  
 Flow characteristic A-AB: \_\_\_\_\_ EQM  
 Flow characteristic B-AB: \_\_\_\_\_ Linear  
 Stroke: \_\_\_\_\_ DN 65, 25 mm  
 \_\_\_\_\_ DN 80-150, 45 mm  
 Rangeability  $K_v/K_v^{min}$ : \_\_\_\_\_ >50  
 Leakrate A-AB: \_\_\_\_\_ 0.03% of  $K_v$ s  
 Leakrate B-AB: \_\_\_\_\_ 2% of  $K_v$ s  
 $\Delta P_{max}$ : \_\_\_\_\_ Mixing: 200 kPa (2 bar)  
 \_\_\_\_\_ Diverting: 70 kPa (0.7 bar)  
 Media temperature: \_\_\_\_\_ max. +150°C  
 \_\_\_\_\_ min. -10°C  
 Connection: \_\_\_\_\_ Flange, ISO 7005-2

Material DN 65 - 150  
 Body: \_\_\_\_\_ Grey cast iron EN-JL 1040  
 Stem: \_\_\_\_\_ Stainless steel DIN 1.4305  
 Plug: \_\_\_\_\_ Brass CW617N  
 Seat: \_\_\_\_\_ Grey cast iron EN-JL 1040  
 Seat seal: \_\_\_\_\_ Metallic  
 Packing box seal: \_\_\_\_\_ EPDM

CE DN65-150 PED 97/23/EC, article 9, group 2

# CONTROL VALVE PN16

## SERIES SERIE VLA300, VLA400 AND VLB300

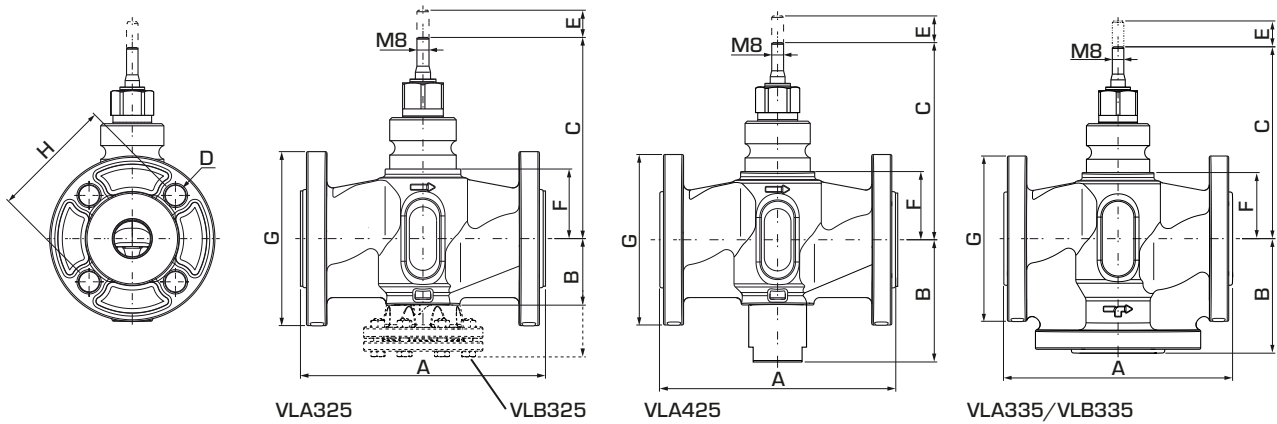

### 2-WAY CONTROL VALVE SERIES VLA325/VLB325

Art. No.	Reference	DN	Kvs *	A	B	C	D	E	F	G	H	Weight [kg]
21200100	VLA325	15	1.6	130	42	123	4x14	20	38	95	65	2.1
21200200			2.5									
21200300			4									
21200400		20	6.3	150	44	126	4x14	20	41	105	75	2.6
21200500		25	10	160	44	131	4x14	20	46	115	85	3.2
21200600		32	16	180	58	144	4x19	20	60	140	100	4.6
21200700		40	25	200	60	146	4x19	20	61	150	110	5.8
21200800	50	38	230	74	161	4x19	20	76	165	125	8.0	
21220100	VLB325	65	63	290	175	155	4x18	25	95	185	145	23.0
21220200		80	100	310	187	165	8x18	45	105	200	160	30.0
21220300		100	130	350	207	176	8x18	45	116.5	220	180	45.6
21220400		125	200	400	234	199	8x18	45	139	250	210	55.0
21220500		150	300	480	277	217	8x22	45	157	285	240	71.0

### 2-WAY CONTROL VALVE SERIES VLA425 WITH PRESSURE BALANCED PLUG

Art. No.	Reference	DN	Kvs *	A	B	C	D	E	F	G	H	Weight [kg]
21201700	VLA425	25	10	160	83	131	4x14	20	46	115	85	3.4
21201800		32	16	180	88	144	4x19	20	60	140	100	5.0
21201900		40	25	200	84	146	4x19	20	61	150	110	6.1
21202000		50	38	230	100	161	4x19	20	76	165	125	8.3

### 3-WAY CONTROL VALVE SERIES VLA335/VLB335

Art. No.	Reference	DN	Kvs *	A	B	C	D	E	F	G	H	Weight [kg]
21200900	VLA335	15	1.6	130	65	123	4x14	20	38	95	65	2.5
21201000			2.5									
21201100			4									
21201200		20	6.3	150	75	126	4x14	20	41	105	75	3.2
21201300		25	10	160	80	131	4x14	20	46	115	85	3.8
21201400		32	16	180	90	144	4x19	20	60	140	100	6.6
21201500		40	25	200	100	146	4x19	20	61	150	110	7.5
21201600	50	38	230	115	161	4x19	20	76	165	125	10.0	
21221100	VLB335	65	63	290	145	155	4x18	25	95	185	145	19.0
21221200		80	100	310	155	165	8x18	45	105	200	160	24.0
21221300		100	130	350	175	176	8x18	45	116.5	220	180	32.0
21221400		125	200	410	200	199	8x18	45	139	250	210	46.0
21221500		150	300	480	240	217	8x22	45	157	285	240	61.0

\* Kvs-value in m<sup>3</sup>/h at a pressure drop of 1 bar.

# CONTROL VALVE PN16

## SERIES SERIE VLA300, VLA400 AND VLB300

### VALVE CHARACTERISTICS, DN15-50

2-way valves, DN15-50

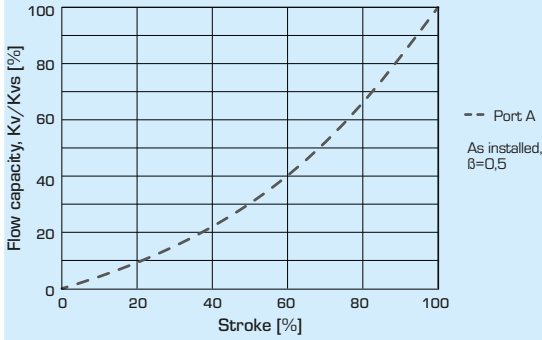

3-way valves, DN15-50

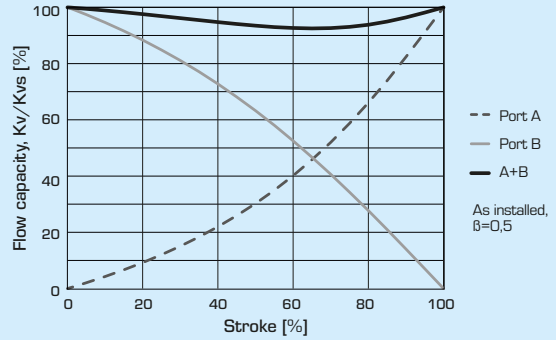

### DIFFERENTIAL PRESSURE DROP CHARACTERISTICS, DN15-50 (mixing)

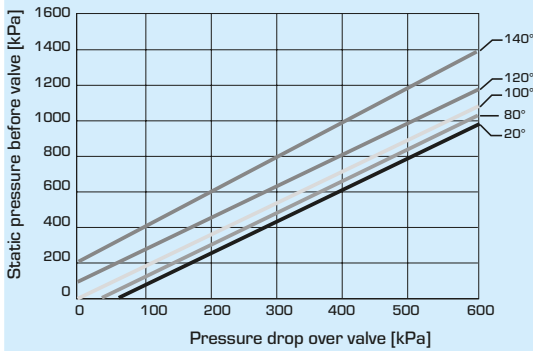

Pressure drop limit where cavitation might occur. Is dependent of valve inlet pressure and temperature of water.

### VALVE CHARACTERISTICS, DN65-150

2-way valves, DN65-150

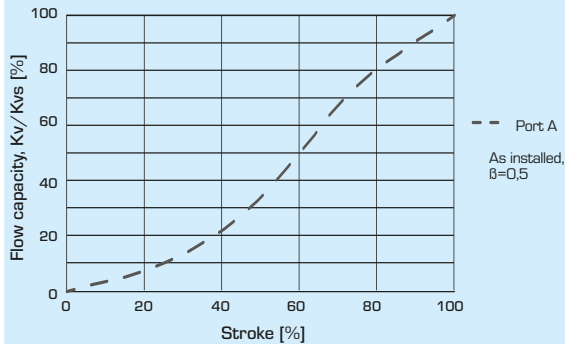

3-way valves, DN65-150

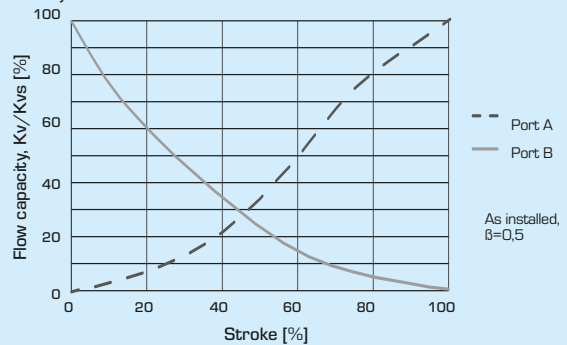

# CONTROL VALVE PN16

## SERIE SERIE VLA300, VLA400 AND VLB300

**FLOW CHART**

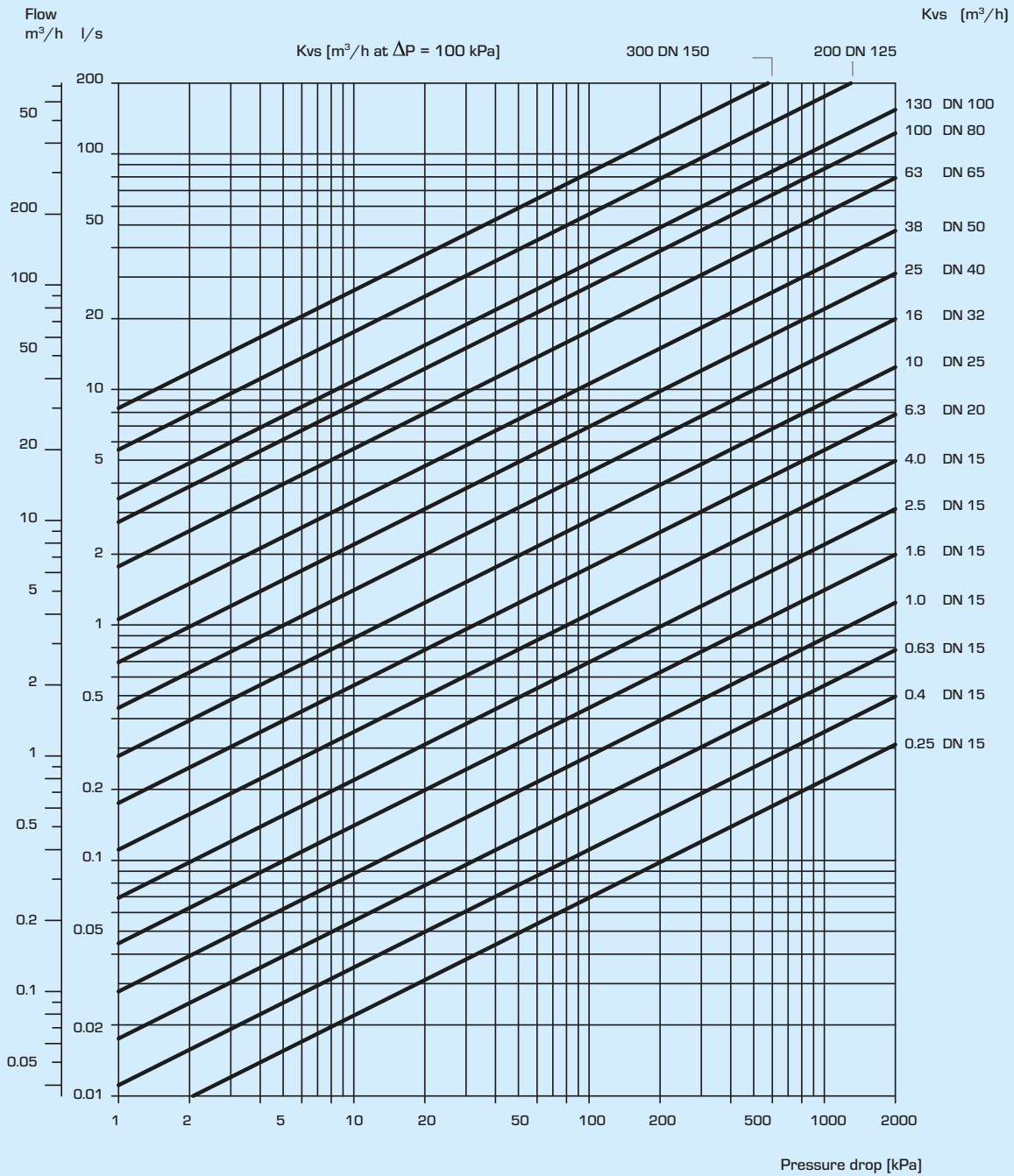

*To be considered: As both the viscosity and the thermal conduction are affected when glycol is added to the system water, this fact has to be considered when dimensioning the valve. A good rule is to choose one size higher Kv-value when 30 – 50% glycol is added. A lower concentration of glycol may be disregarded. N.B.1 Maximum 50% glycol for freezing protection and oxygen absorbing compounds are allowed as additives.*

# CONTROL VALVE PN16

## SERIE SERIE VLA300, VLA400 AND VLB300

### INSTALLATION EXAMPLES

#### 2-WAY CONTROL VALVES

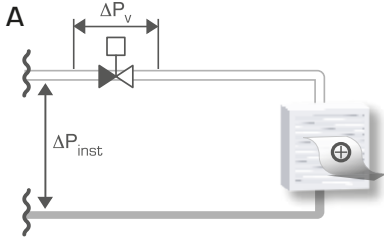

Installation without local circulating pump

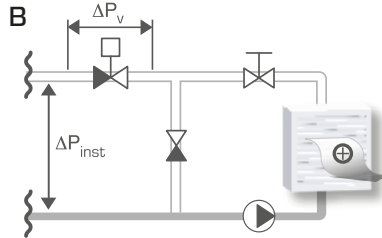

Installation with local circulating pump

#### 3-WAY CONTROL VALVES

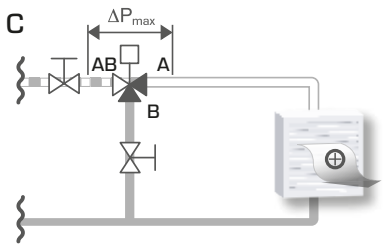

Circuit without local circulation pump

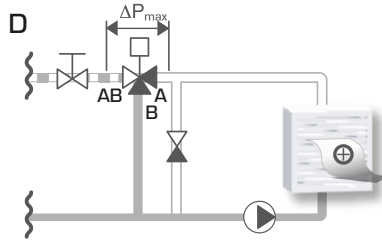

Circuit with local circulation pump

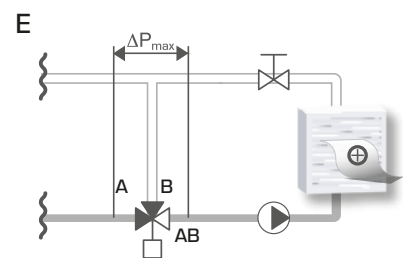

Circuit with local circulating pump