

F74CS / FN74CS

Reverse rinsing fine filter

Product specification sheet

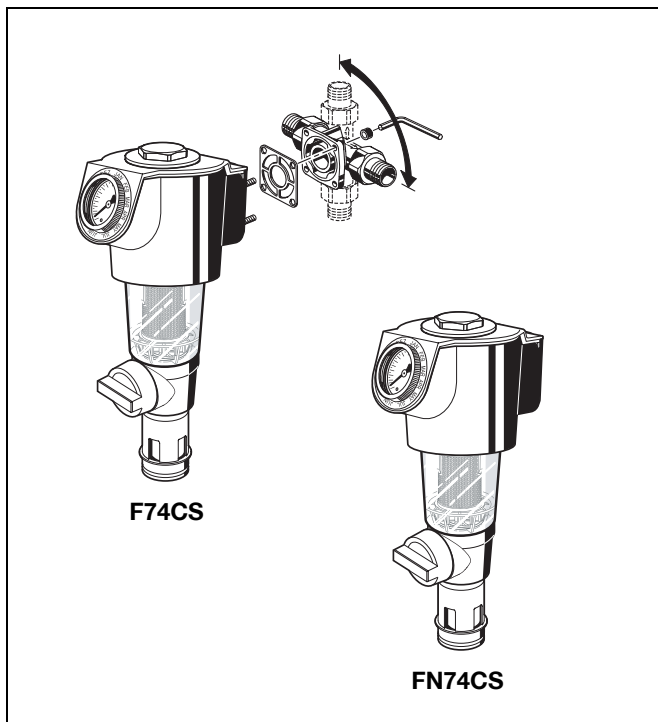

Application

The reverse rinsing filters ensure a continuous supply of filtered water. The fine filter prevents the ingress of foreign bodies, for example rust particles, strands of hemp and grains of sand.

The fine filters are used in systems where an existing pressure reducing valve is fitted or where one is not required. Both horizontal and vertical installation is possible.

Special Features

- DVGW-approval requested
- Filtered water supplied even during reverse rinsing
- Patented reverse rinsing system - fast and thorough cleaning of the filter with small amount of water
- Memory ring indicates when next manual reverse rinsing is due
- Automatic reverse rinsing actuator with bayonet connector can be retrofitted
- Large filter surface
- Shock resistant clear synthetic material filter bowl enables easy checking of filter contamination
- Filter insert fully replaceable
- Standardised discharge connection
- Meets KTW recommendations for potable water

Range of Application

Medium	Water
Inlet pressure	Max. 16.0 bar (up to 12.0 bar long-term)

The filter is constructed for drinking water installations. In case of a process water application the filter has to be proven individually.

For maintaining the measuring accuracy of the manometer, a continuous maximum pressure load of 12.0 bar is permitted.

Technical Data

Installation position	Vertical or horizontal, with filter bowl downwards
Operating pressure	Min. 1.5 bar; Max. 16.0 bar
Operating temperature	5 - 30 °C
Connection size R with rotatable connector piece	1/2, 3/4", 1", 1 1/4"

Construction

The filter combination comprises:

- Housing with pressure gauge
- Clear filter bowl
- Fine filter
- Ball valve with drain connection
- Reverse rinsing handle
- Rotatable connector piece, flange sealing, connecting nuts and fittings (F74CS only)
- Memory ring
- Covers
- Wrench for filter bowl and spring bonnet
- Allen key WS6

Materials

- High quality synthetic material housing
- Synthetic material filter mesh carrier, reverse rinsing handle and covers
- Dezincification resistant brass connector piece (F74CS only)
- Stainless steel fine filter
- Shock-resistant, clear transparent synthetic material filter bowl
- Fibre-reinforced NBR diaphragm
- EPDM sealing washers

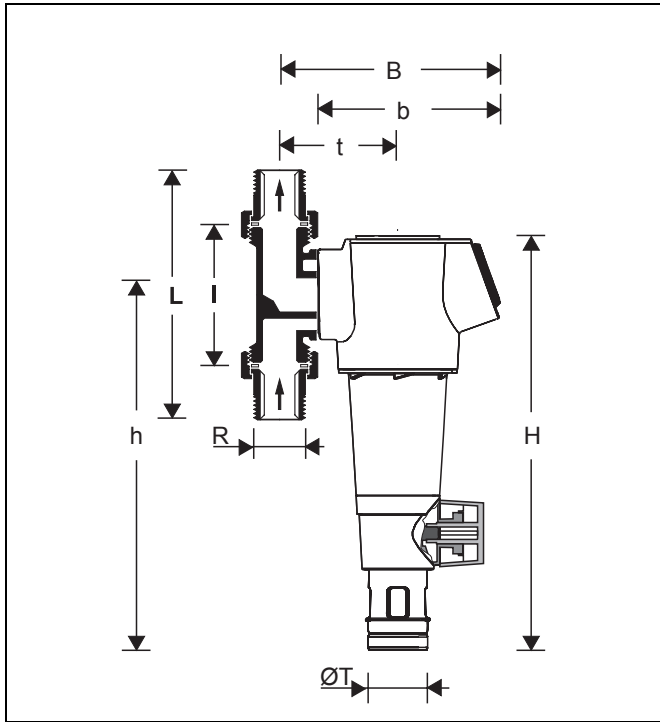

Method of Operation

The filter insert comprises an upper part and a lower combination section. When in the „filtering“ position, the small upper filter is closed so that the water can only pass through the main filter from outside to inside. When the ball valve is opened for reverse rinsing, the filter is pushed downwards until the water supply to the outer side of the main filter is stopped. Simultaneously, the water flow is opened to the upper part of the filter. The water needed for cleaning the filter passes through the upper sieve, the rotating impeller and the main filter from inside to outside. By this means, the filter is fully cleaned over its whole surface area at the full inlet pressure. The filter automatically switches over to the operating position when the ball valve is closed again.

Options

- F74CS-...AA = With rotatable connector piece, filter mesh size 95/110 µm
- F74CS-...AC = With rotatable connector piece, filter mesh size 50 µm
- F74CS-...AD = With rotatable connector piece, filter mesh size 200 µm
- Connection size
- FN74CS-1A = Retrofit version without rotatable connector piece, filter mesh size 95/110 µm

Connection size	R	1/2"	3/4"	1"	1 1/4"
Weight	approx. kg	2.1	2.1	2.3	2.6
Dimensions	mm				
	H	353	353	353	353
	h	298	298	298	298
	L	150	158	179	197
	l	90	90	100	105
	B	178	178	178	182
	b	150	150	150	150
	t	92	92	92	96
	ØT	50	50	50	50
Flow value at Δp = 0.2 bar	m ³ /h	2.3	3.4	3.8	4.0
Flow value at Δp = 0.5 bar	m ³ /h	3.6	5.5	6.0	6.3
k _{vs} -value		5.1	7.7	8.5	9.0
DVGW-Approval No.		requested			

Accessories

DA74C/CS Rotatable connector piece

For connection of retrofit filters and filter combinations

DA74CS for connection size 1/2"

DA74C for connection sizes 3/4", 1", 1 1/4"

Z74S-AN Automatic reverse rinsing actuator

For automatic filter cleaning at presettable intervals

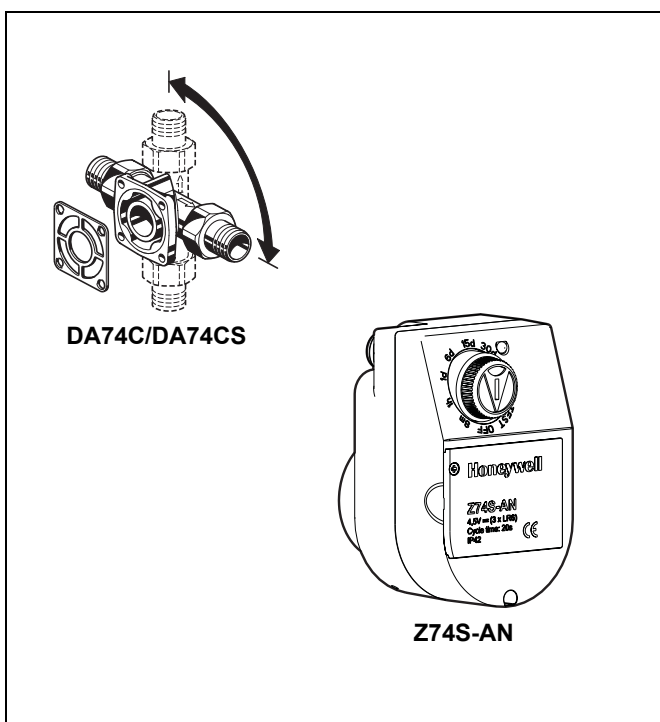

Installation Example

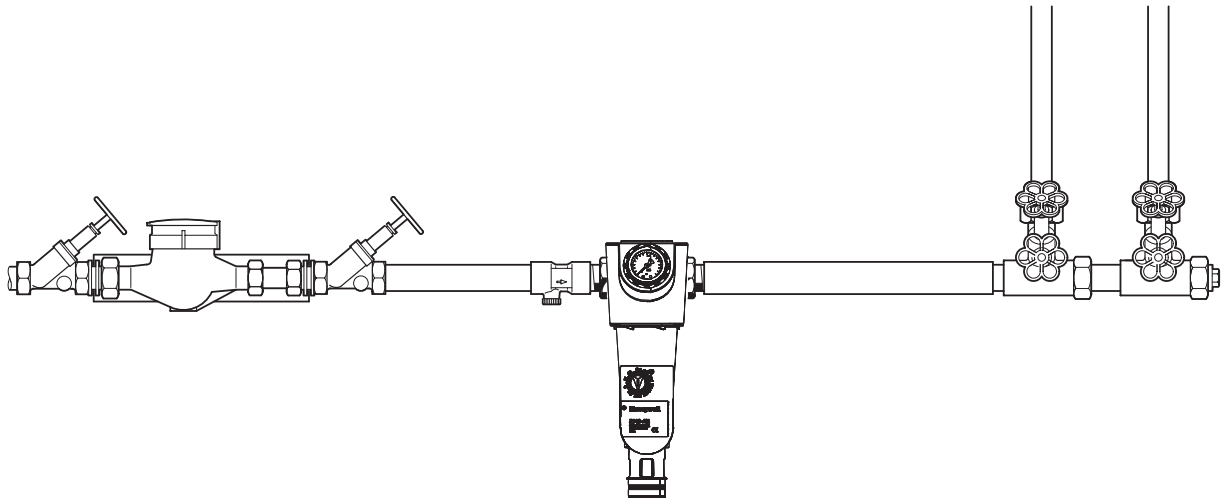

Installation Guidelines

- The installation site has to be frost-proof and the protection of the device from chemicals, paints, detergents, solvents and their vapours and environmental influences must be guaranteed.
- Install in horizontal or vertical pipework with filter bowl downwards
 - o This position ensures optimum filter efficiency
- Install shutoff valves
- Ensure good access
 - o Pressure gauge can be read off easily
 - o Degree of contamination can be seen with clear filter bowl
 - o Simplifies maintenance and inspection
- It is recommended that a straight section of pipework at least five times the nominal valve size is provided after the filter (according to DIN EN 806, part 2)
- Fit immediately after water meter

Typical Applications

Filters of this type are suitable for all types of house-hold installations. They can also be used for commercial and industrial applications within the limits of their specifications.

Fine filters of this type are installed:

- Where there is existing metal or plastics pipework
- For installation in horizontal or vertical pipework
- As replacement for an existing filter
- Where space is a problem, particularly where clearance from the wall is limited

Flow Diagram

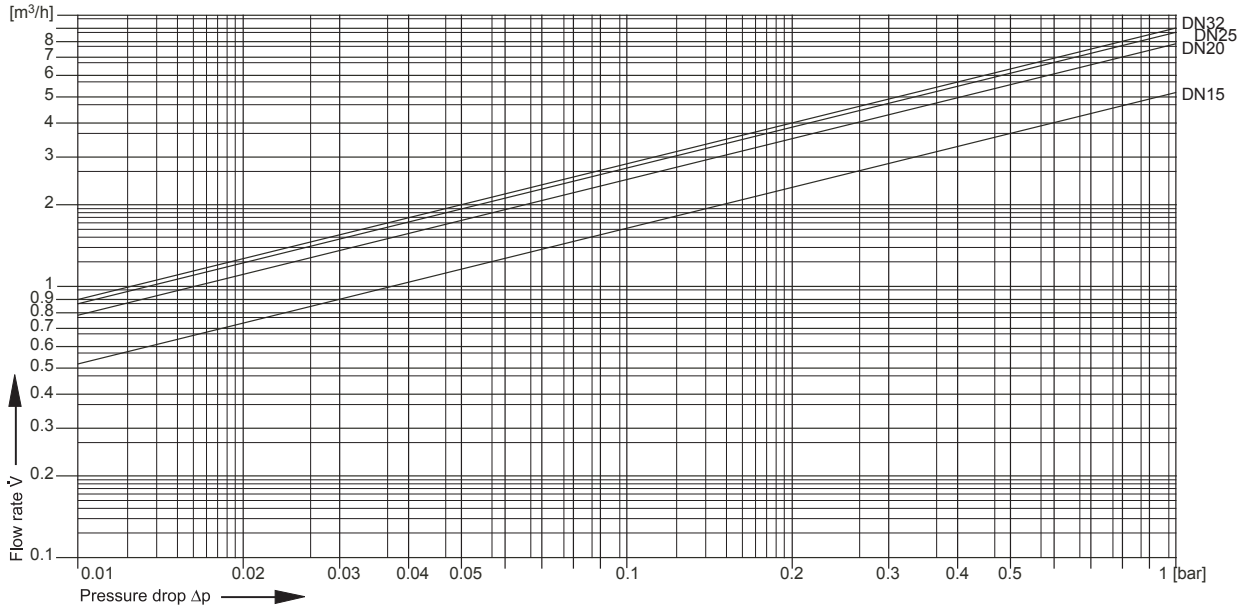

EN0H-1157GE23 R0111 • Subject to change

Fine filters FK74CS / FKN74CS (from 2010 onwards)

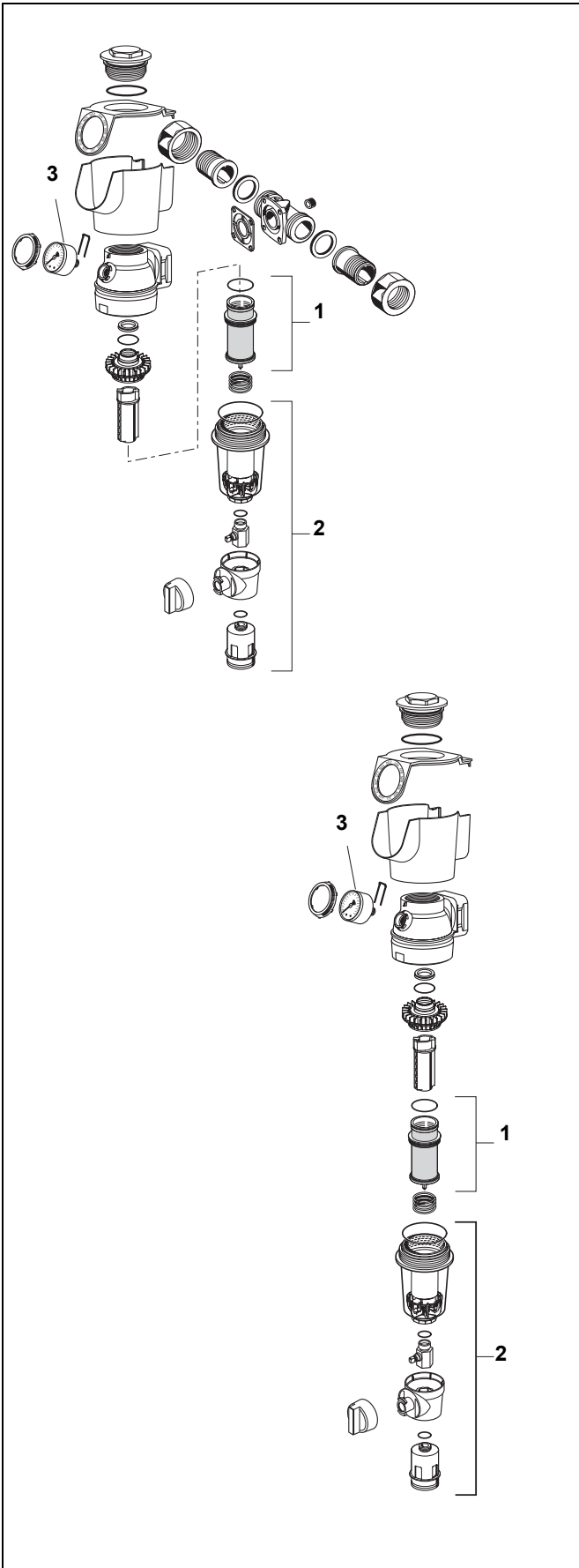

No. Description

Dimension Part No.

- | | | |
|----------|--|--|
| 1 | Filter insert complete
Filter mesh 95/110 µm
Filter mesh 50 µm
Filter mesh 200 µm | 1/2" - 1 1/4"
AF74-1A
AF74-1C
AF74-1D |
| 2 | Clear filter bowl
complete | 1/2" - 1 1/4" KF74CS-1A |
| 3 | Pressure gauge
rear connection thread G1/4"
Range 0 - 16 bar | M74CS-A16 |
| 4 | Wrench for removing filterbowl and
spring bonnet (no fig.) | ZR74CS |

Automation and Control Solutions

Honeywell GmbH
 Hardhofweg
 D-74821 Mosbach
 Phone: (49) 6261 810
 Fax: (49) 6261 81309
<http://europe.hbc.honeywell.com>
www.honeywell.com

Manufactured for and on behalf of the
 Environmental and Combustion Controls Division
 of Honeywell Technologies Sàrl, Z.A. La Pièce 16,
 1180 Rolle, Switzerland by its Authorised Repre-
 sentative Honeywell GmbH
 EN0H-1157GE23 R0111
 Subject to change without notice
 © 2011 Honeywell GmbH

Honeywell